

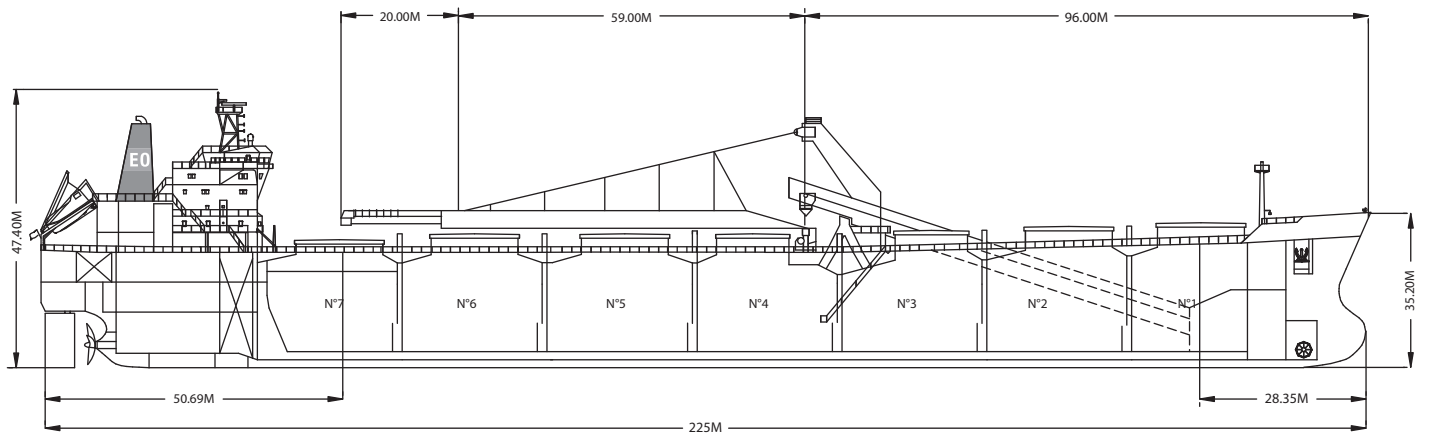

The Sophie Oldendorff unloading coal in Puerto Rico

Built	2000
Classification	DNV +1A1
Length Overall	225.00 metres
Breadth Moulded	32.18 metres
Depth Moulded	19.51 metres
Total Hold Capacity (including hatches)	66,333.24 metres
Deadweight	70,034 tonnes
Draft	14.42 metres
Gross Tonnage	41,428 tonnes
Net Tonnage	19,161 tonnes
Bow Thruster	1325 kW
Length of Boom	79.00 metres
Discharge Rate	-Coal	4,000 tonnes/hr
	-Ore	6,000 tonnes/hr

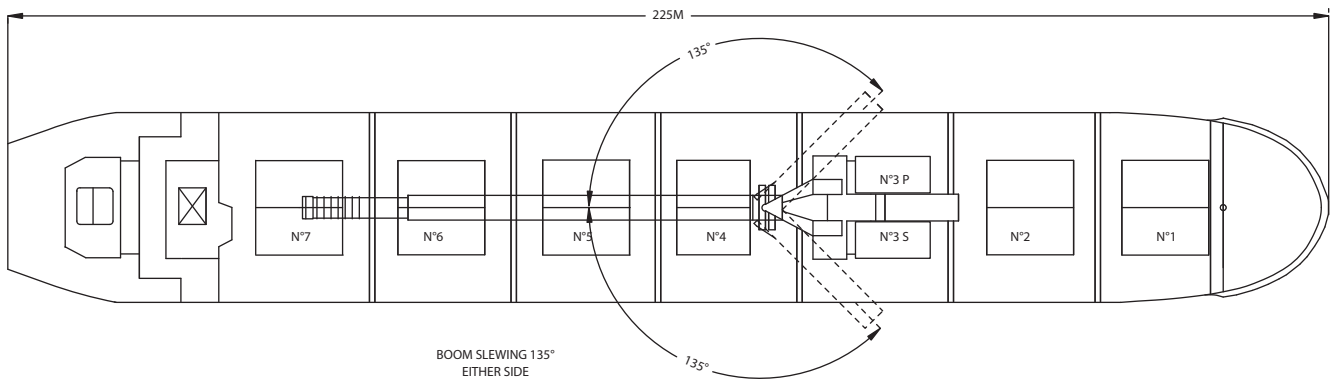
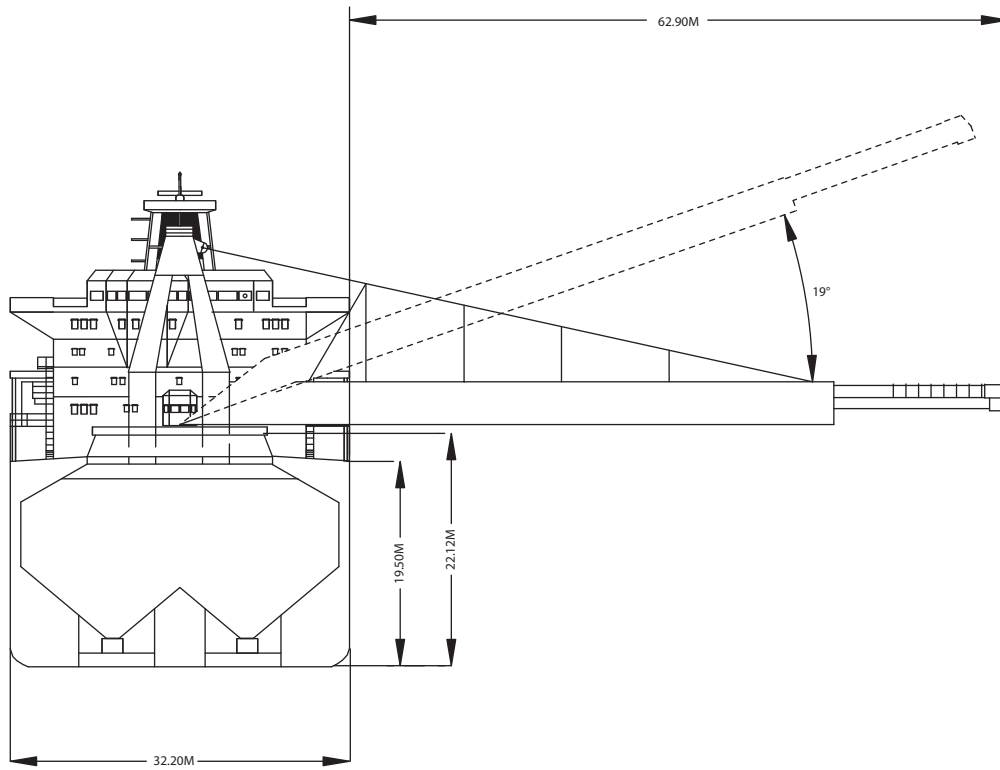

0981-04 08/19/04

Air Drafts												
(metres)												
Draft Condition	Stem	Foremast	Hatches			Cargo Gear	Main Mast		Funnel	Stem	Other Obstruction*	Maximum
			Forward	Midship	Aft		Deployed	Lowered				
Keel	26.36	35.40	24.30	22.46	21.55	43.11	47.28	N/A	42.7	20.00	25.90	47.28
Light Ship	24.55	33.37	22.27	19.00	16.69	40.10	43.05	N/A	38.3	15.34	23.05	43.05
Normal Ballast 50% Bunker	18.71	27.65	16.55	13.53	12.65	34.94	38.54	N/A	33.9	11.10	17.81	38.54
Fully Loaded 50% Bunker	12.21	21.20	10.10	10.11	6.87	28.74	32.67	N/A	28.1	5.32	11.56	32.67

*Incline Belt Gallery max. elevation (above Keel) over aft part of Hold No.3 (may affect loading of the opposite side of the Hold)

Hatch and Hold Specifications									
Hold Number	1	2	3	4	5	6	7	TOTAL	
Hold Volumes (cubic metres)									
Cubic	8,064.2	9,779.9	9,187.7	9,088.4	9,705.0	9,772.2	8664.8	64262.1	
Maximum Grain	8,335.9	10,044.6	9,545.0	9,556.1	9,925.4	9,992.6	8,933.7	66333.2	
Grain in way of Hatch	271.7	264.6	357.3	467.7	220.4	220.4	268.9	2071.2	
Hold Openings (metres)									
Number of Openings	1	1	2	1	1	1	1	1	8
Opening Length	14.76	14.76	12.30	12.30	14.76	14.76	14.76	14.76	
Opening Width	16.00	16.00	5.80	16.00	16.00	16.00	16.00	16.00	
Coaming Height above Keel	23.90	23.20	22.50	22.03	22.10	22.10	21.10	21.10	
Hatch Information (metres)									
Description	Side-rolling Panels	Side-rolling Panels	Side-rolling Panels	Side-rolling Panels	Side-rolling Panels	Side-rolling Panels	Side-rolling Panels	Side-rolling Panels	
Operation	Hydraulic	Hydraulic	Hydraulic	Hydraulic	Hydraulic	Hydraulic	Hydraulic	Hydraulic	
Hatch Length	15.06	15.06	12.62	12.60	15.06	15.06	15.06	15.06	
Hatch Width	8.15	8.15	6.12	8.15	8.15	8.15	8.15	8.15	
Hatch Top Height above Keel	24.85	24.15	23.45	22.97	23.05	23.05	22.05	22.05	

Cargo Handling Equipment
• Telescopic boom
• A shuttle-type conveyor is fitted at the toe and extends boom 20m
• Two 3.5 m/s hold conveyors
• Two 3.5 m/s transfer conveyors. One 4.0 m/s inclined belt.
• All belts 1.8m wide with 35 degree trough
• Dust Suppression: All holds and transfer points are fitted with positive air pressure dust collectors plus water sprayers and surfactant applicators.
• Unloader Inner Boom Length: 59.00 metres
• Discharge Rate - Coal: 4,000 tonnes/hr - Ore: 6,000 tonnes/hr
• Maximum Boom Outreach: 62.90 metres

Consumption (tonnes per day)				
	Speed		Main Engine	Generators
	Loaded	Ballast	IFO	MDO
Sea	15.3 knots	15.9 knots	46	0.1
Port / Anchorage			5	0.3
Loading / Discharge			7	0.3

For more information on this ship please visit www.cslint.com

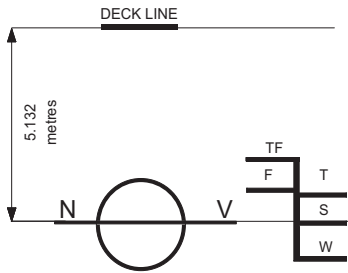

ASSIGNED DRAFTS			
Season	Draft (metre)	Displ. (tonnes)	DWT (tonnes)
TF	15.05	89,077	71,530
F	14.75	87,329	69,782
T	14.72	89,575	72,028
S	14.42	87,584	70,037
W	14.12	85,599	68,052

Light Ship
17,547 tonnes

DEADWEIGHT SCALE									
DRAFT				DISPLACEMENT (tonnes)	TPC (tonnes)	DEADWEIGHT (tonnes)	DRAFT		
Sea Water		Fresh Water					Sea Water		
(metre)	(feet)	(metre)	(feet)				(feet)	(metre)	
	48	15		90,000			48		
14	46		48		66		46	14	
	44	14	46	80,000			44		13
13	42		44			60,000	42		
	40	13	42				40		12
12	38		40	70,000			38		
	36	12	38			50,000	36		11
11	34		36		64		34		
	32	11	34	60,000			32		10
10	30		32			40,000	30		9
	28	10	30				28		9
9	26		28	50,000	62		26		8
	24	9	26			30,000	24		8
8	22		24	40,000			22		7
	20	8	22			20,000	20		6
7	18		20				18		6
	16	7	18	30,000	60	10,000	16		5
6	14		16				14		5
	12	6	14				12		4
5	10		12	20,000			10		4
	8	5	10				8		3
4			8						3
		4							8
3									8
		3			58				8
2									8
		2							8
1									8
		1							8
0									8

0981-04 08/19/04



For more information on this ship please visit www.cslint.com