

MV HONOURABLE HENRY JACKMAN



Entering Boston Harbour

Built1981, rebuilt with new forebody in 2007
Classification100A1 Bulk Carrier, Double Skinned, Arrangement for Self Discharging,ESP Shipright (SDA,FDA,CM),ESP,LI,LMC,UMS
Length Overall244.72 metres
Breadth Moulded32.22 metres
Depth Moulded20.20 metres
Total Hold Capacity (including structure)75,242.60 cubic metres
Deadweight75,597.42 tonnes
Draft (summer)13.50 metres
Gross Tonnage46,191 tonnes
Net Tonnage17,218 tonnes
Bow Thruster1,800 kW
Length of Boom80.00 metres
Discharge Rate5,000 tonnes/hr

MV HONOURABLE HENRY JACKMAN

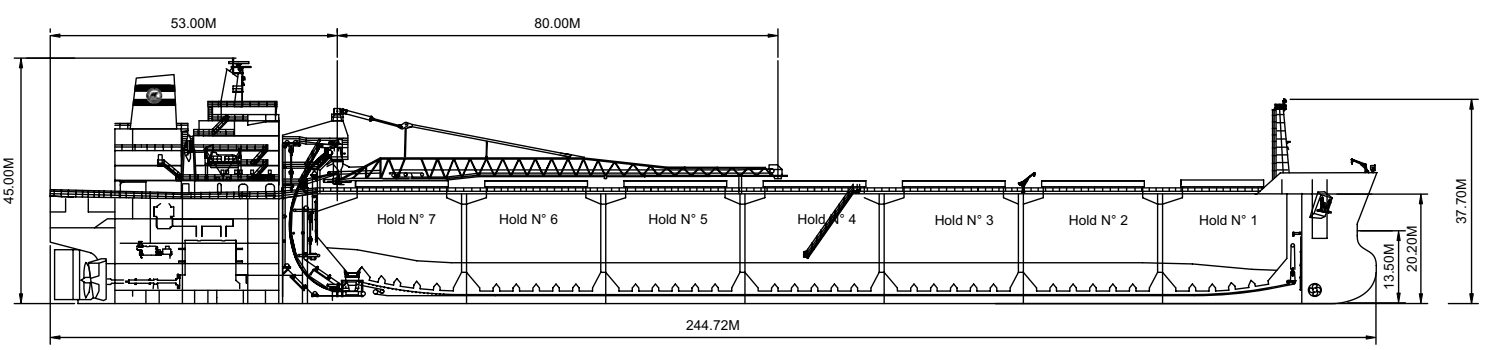
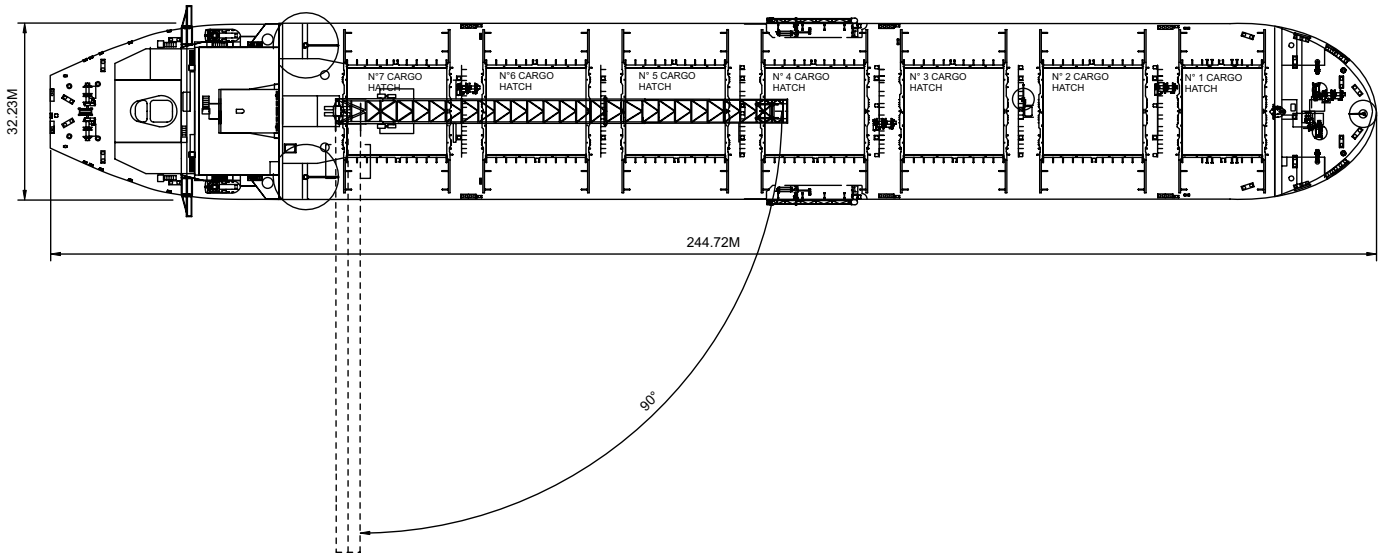
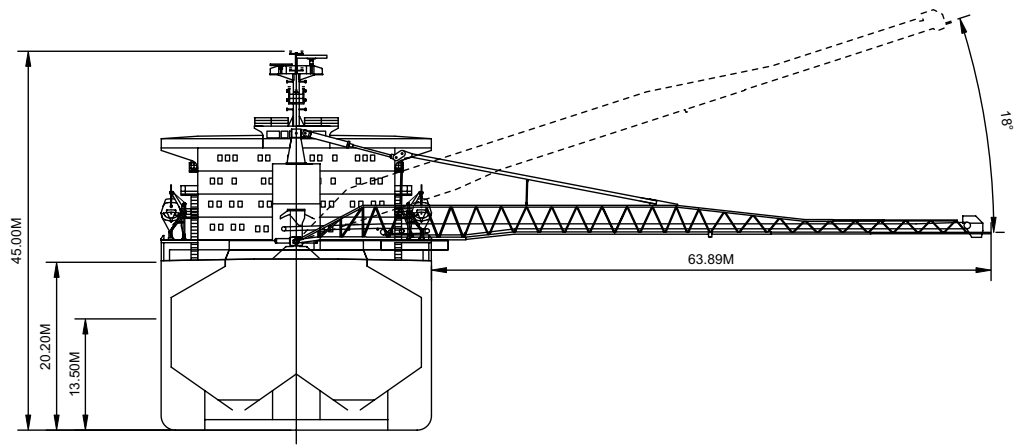

0981-04 09/06/07

Air Drafts (metres)												
Draft Condition	Radio Aerial	Foremast	Hatches			Cargo Gear	Main Mast		Funnel	Stern	Other Obstruction*	Maximum
			Forward	Midship	Aft		Deployed	Lowered				
Keel	24.10	37.70	22.15	22.15	22.15	N/A	45.00	N/A	44.20	20.40	N/A	45.00
Light Ship	23.30	37.20	21.10	19.40	18.02	N/A	40.80	N/A	39.90	15.80	N/A	40.80
Normal Ballast 50% Bunker	18.20	30.80	17.41	15.22	13.99	N/A	36.30	N/A	35.40	11.40	N/A	36.30
Fully Loaded 50% Bunker	10.60	24.20	8.75	8.75	8.75	N/A	31.50	N/A	30.70	6.90	N/A	31.50

Hatch and Hold Specifications									
Hold Number	1	2	3	4	5	6	7	TOTAL	
Hold Volumes (cubic metres)									
Cubic	8,993.6	11,136.0	11,139.8	11,139.8	11,139.8	11,139.8	10,177.7	74,866.4	
Maximum Grain	9,038.8	11,191.9	11,195.8	11,195.8	11,195.8	11,195.8	10,228.8	75,242.6	
Grain in way of Hatch	45.2	55.9	56.0	56.0	55.9	56.0	51.1	376.2	
Hold Openings (metres)									
Number of Openings	1	1	1	1	1	1	1	7	
Opening Length	14.64	18.30	18.30	18.30	18.30	18.30	16.47		
Opening Width (Normal)	16.00	16.00	16.00	16.00	16.00	16.00	16.00		
Opening Width (Extra)	17.10	17.10	17.10	17.10	17.10	17.10	17.10		
Coaming Height above Keel	21.50	21.50	21.50	21.50	21.50	21.50	21.50		
Hatch Information (metres)									
Description	Side Rolling Panels	Side Rolling Panels	Side Rolling Panels	Side Rolling Panels	Side Rolling Panels	Side Rolling Panels	Side Rolling Panels	Side Rolling Panels	
Operation	Hydraulic	Hydraulic	Hydraulic	Hydraulic	Hydraulic	Hydraulic	Hydraulic	Hydraulic	
Hatch Length	14.97	18.63	18.63	18.63	18.63	18.63	18.63	16.80	
Hatch Width	16.34	16.34	16.34	16.34	16.34	16.34	16.34	16.34	
Hatch Top Height above Keel	22.15	22.15	22.15	22.15	22.15	22.15	22.15	22.15	

Cargo Handling Equipment
• Fixed Type Conveyor along Boom
• Two VFD (0.5 m/s to 2.6 m/s) Tunnel Conveyers
• Two 2.6 m/s Transfer Conveyers
• One 3.8 m/s Boom Conveyor
• One VFD (1.43 m/s to 4.32 m/s) C-Loop Elevator
• Tunnel Belts: 2,134 mm wide
• Boom Belt: 1,981 mm wide
• Transfer Belt: 2,134 mm wide
• C-Loop Elevator Width : Outer 2,591 mm and Inner 2,743 mm
• Dust Suppression: Boom and Transfer Points
• Discharge Rate: 5,000 mt/h or 5,300 cu.m/h, whichever occurs first
• Maximum Boom Outreach: 63.89 metres

Consumption (tonnes per day)				
	Speed		Main Engine	Generators
	Loaded	Ballast	IFO	MDO
Sea	14.5	15.5	45	2.5
Port / Anchorage			N/A	5.0 / 2.5
Loading / Discharge			N/A	5.0 / 7.5

For more information on this ship please visit
www.cslint.com



MV HONOURABLE HENRY JACKMAN

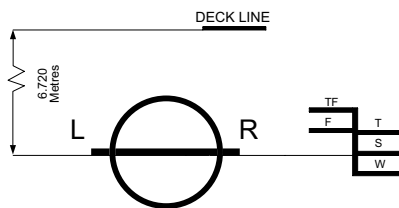

ASSIGNED DRAFTS			
Season	Draft (metre)	Displ. (tonnes)	DWT (tonnes)
TF	14.10	94,247	77,650
F	13.81	92,222	75,625
T	13.78	94,293	77,695
S	13.50	90,229	75,631
W	13.22	90,168	73,571

Light Ship
16,597 tonnes

DEADWEIGHT SCALE									
DRAFT				DISPLACEMENT (tonnes)	TPC (tonnes)	DEADWEIGHT (tonnes)	DRAFT		
Sea Water		Fresh Water					Sea Water		
(metre)	(feet)	(metre)	(feet)				(feet)	(metre)	
18	58		58	120,000	75		58	18	
17	56	17	56			100,000	56	17	
	54		54				54		
16	52	16	52	110,000			52	16	
	50		50			90,000	50		
15	48	15	48	100,000			48	15	
	46		46			80,000	46	14	
	44		44				44		
13	42	13	42	90,000			42	13	
	40		40			70,000	40	12	
	38		38	80,000			38		
	36	11	36			60,000	36	11	
	34		34	70,000			34		
10	32	10	32			50,000	32	10	
	30		30				30	9	
	28	9	28	60,000			28		
	26	8	26		70	40,000	26	8	
	24		24	50,000			24		
	22	7	22			30,000	22	7	
	20	6	20	40,000			20	6	
	18		18			20,000	18		
	16	5	16				16	5	
	14	4	14	30,000			14		
	12		12			10,000	12		
	10	3	10	20,000			10	3	
	8		8			0	8		
2					65			2	

0981-04 09/06/07



For more information on this ship please visit
www.cslint.com